



# PV Project Applets Update

---

**Tom McDermott**  
**MelTran, Inc.**  
**tom@meltran.com**

**UWIG Solar User Group Meeting**  
**October 11, 2011 Maui, Hawaii**

# Screening and Evaluation Tools

- Ratio to feeder minimum load
- Fault current contributions
- Voltage fluctuations
- Grounding
- Transformer connections
- Details – protective relaying, overvoltages, volt/var control

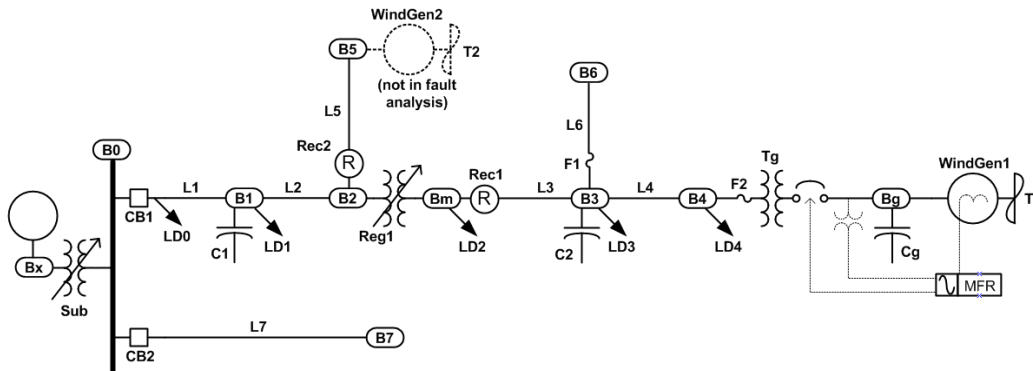

Select Project:	Buffalo Mtn*	<input type="button" value="New"/>	<input type="button" value="Delete"/>
Project Name	Buffalo Mtn*	<input type="button" value="Calc / Update"/>	
<b>Turbine (WTG) Inputs:</b>			
Turbine Type	Vestas V47 / 660	<input type="checkbox"/> Unlisted Type	
Size	673.00	kW	
Generator / Interface	<input type="radio"/> Induction <input checked="" type="radio"/> Wound Rotor <input type="radio"/> DFIG <input type="radio"/> Converter		
Per-unit Fault Current	6.00		
Operating Power Factor	1.00		
Number of Turbines	3		
Average Wind Speed at the Site	6.67	m/s	
<b>Feeder Inputs:</b>			
Substation Transformer	20.00	MVA	
	7.00	% Z	
Feeder Primary Voltage	13.20	kV	
Line Conductor Type	Unbalanced 336 ACSR		
WTG Distance from Sub	50.69	kft	
Peak Load	1.00	MW	
Capacitor Banks	600.00	kVAR	
Regulator Distance from Sub	0.00	kft	
<b>Screening Outputs:</b>			
WTG Portion of Peak Load	201.90	%	
WTG Fault Contribution	0.41	kA	
WTG Portion of System Fault	39.08	%	
FERC Fast-track?	Study Required due to WTG Size, Load Level, Fault Level		
Estimated Capacity Factor	29.7	%	
<b>Flicker Outputs:</b>			
System Apparent Power	23.84	MVA	
System Impedance Angle	66.29	Degrees	
On/Off Voltage Change	3.70	%	
Continuous $P_{ST}$	0.60		
Switching $P_{ST}$	0.37		
Switching $P_{LT}$	0.37		
<input type="button" value="Feeder Simulator..."/>		<input type="button" value="Economic Analysis..."/>	

# 2011-2012 Project Plan

---

- ◆ PV aggregation methods and software tools
- ◆ PV data library
- ◆ Software flickermeter for voltage fluctuations
- ◆ PV inverter models
- ◆ Feeder simulator expansion
  - Larger circuits, more controls and relays
  - Many wind, solar, and other DG units
- ◆ Funding from NREL and CEATI/DALCM

# Solar & Wind Data from CEATI

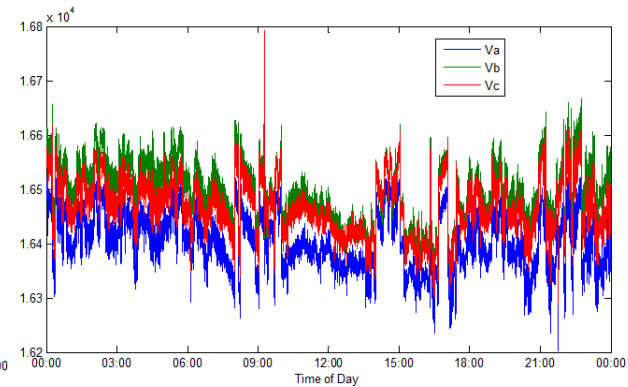
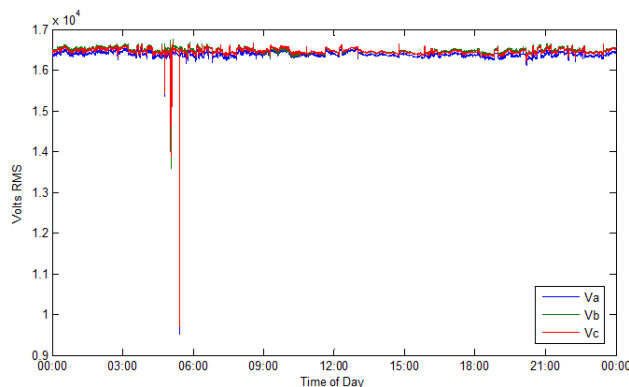
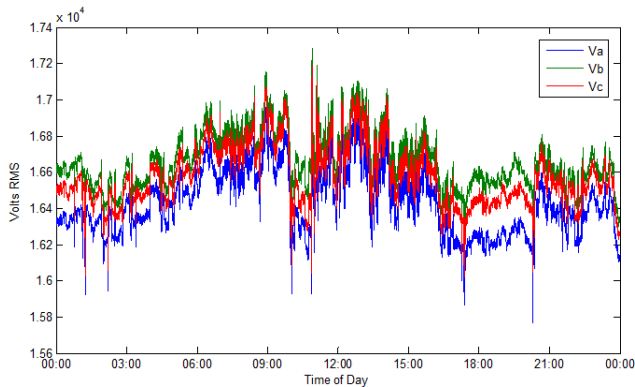
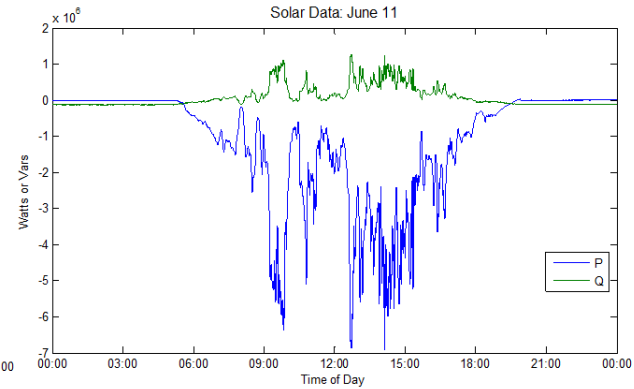
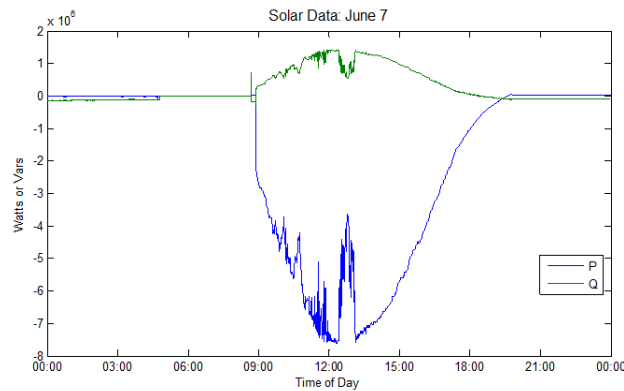
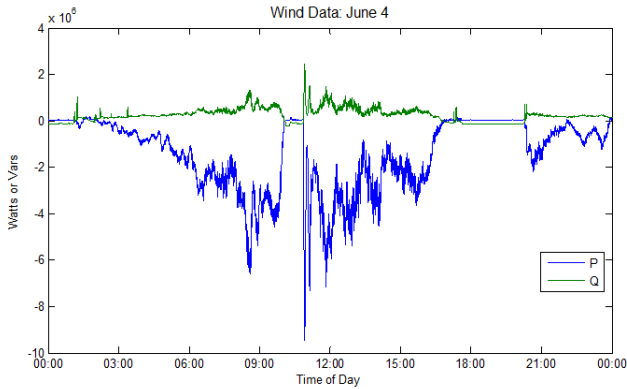

Also Measurement and Instrumentation Data Center

<http://www.nrel.gov/midc/>

# Example Flicker Performance

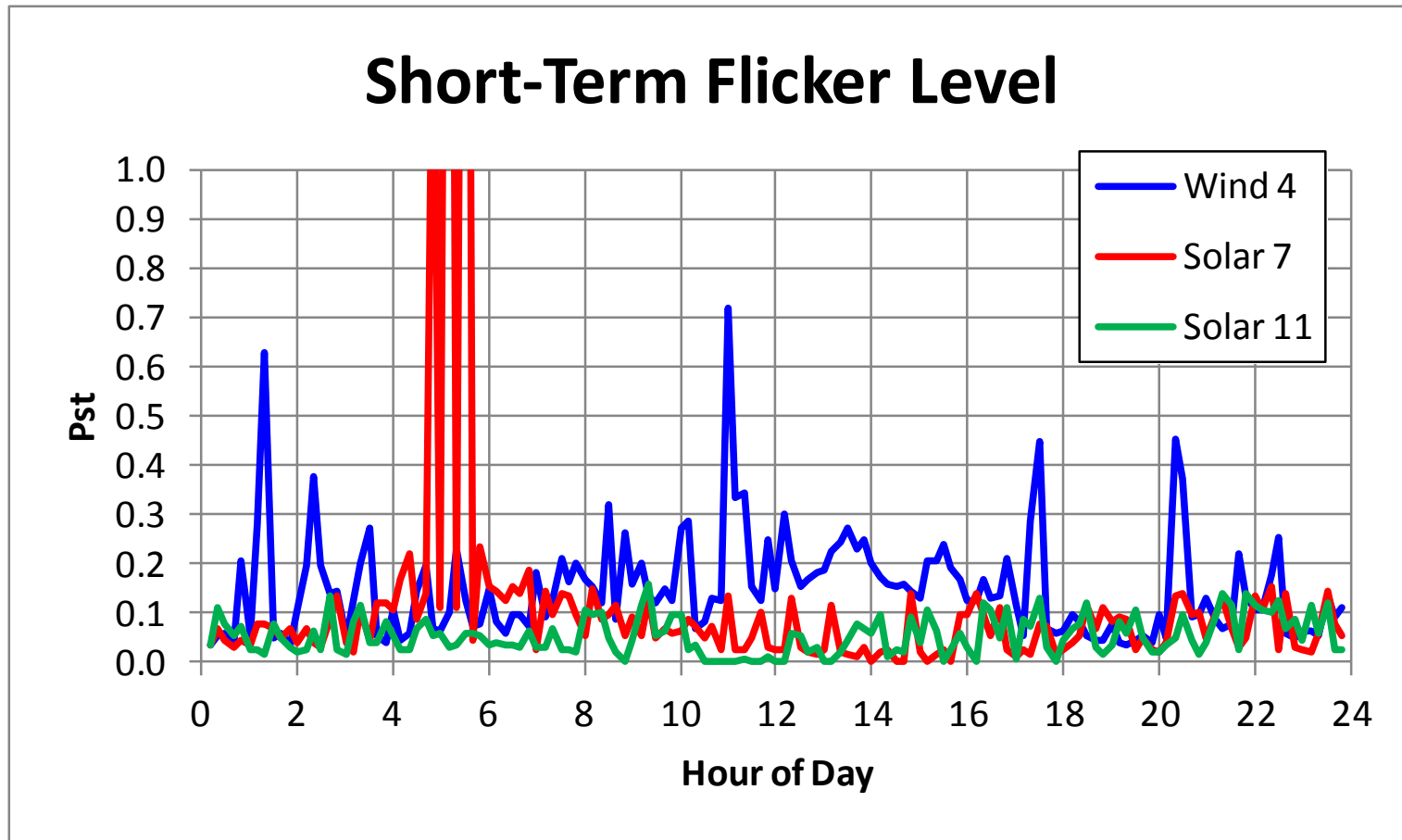

# PV Data Aggregation

- ◆ Method 1: Library of PV plant outputs
  - Range of geographic footprints up to 1500 km<sup>2</sup>
- ◆ Method 2: Assume uncorrelated flicker levels
  - Geometric weighting; if each PV array same size:

$$P_{st-max} = NP_{st-array}$$

$$P_{st-total} = \sqrt{N} P_{st-array}$$

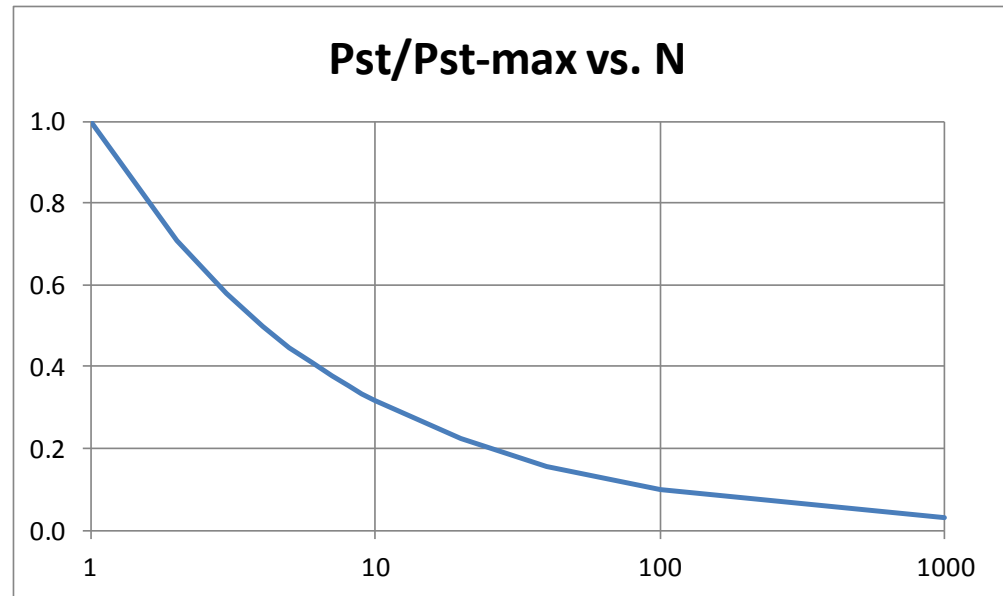

# PV Inverter Modeling

---

- ◆ Need accurate quasi-static models of PV for system studies
  - Variable real and reactive power output
  - Fault contributions
  - Tripping behavior
- ◆ Use vendor-supplied models
  - Minimize re-development costs
  - Prevent access to proprietary information
  - Can run on a Web server, which precludes black-box reverse engineering

# Technical Approach

---

- ◆ Inverter vendors often use Simulink
  - Expensive, especially with necessary add-ons
- ◆ ScicosLab 4.4 is an open-source alternative
  - Block diagrams
  - Modelica language support
  - Code generation
- ◆ Compile and link the model to OpenDSS
  - Extends the newly-added PVSystem component
  - Runs on UWIG Web Server

# Simple PV Model in SciCos

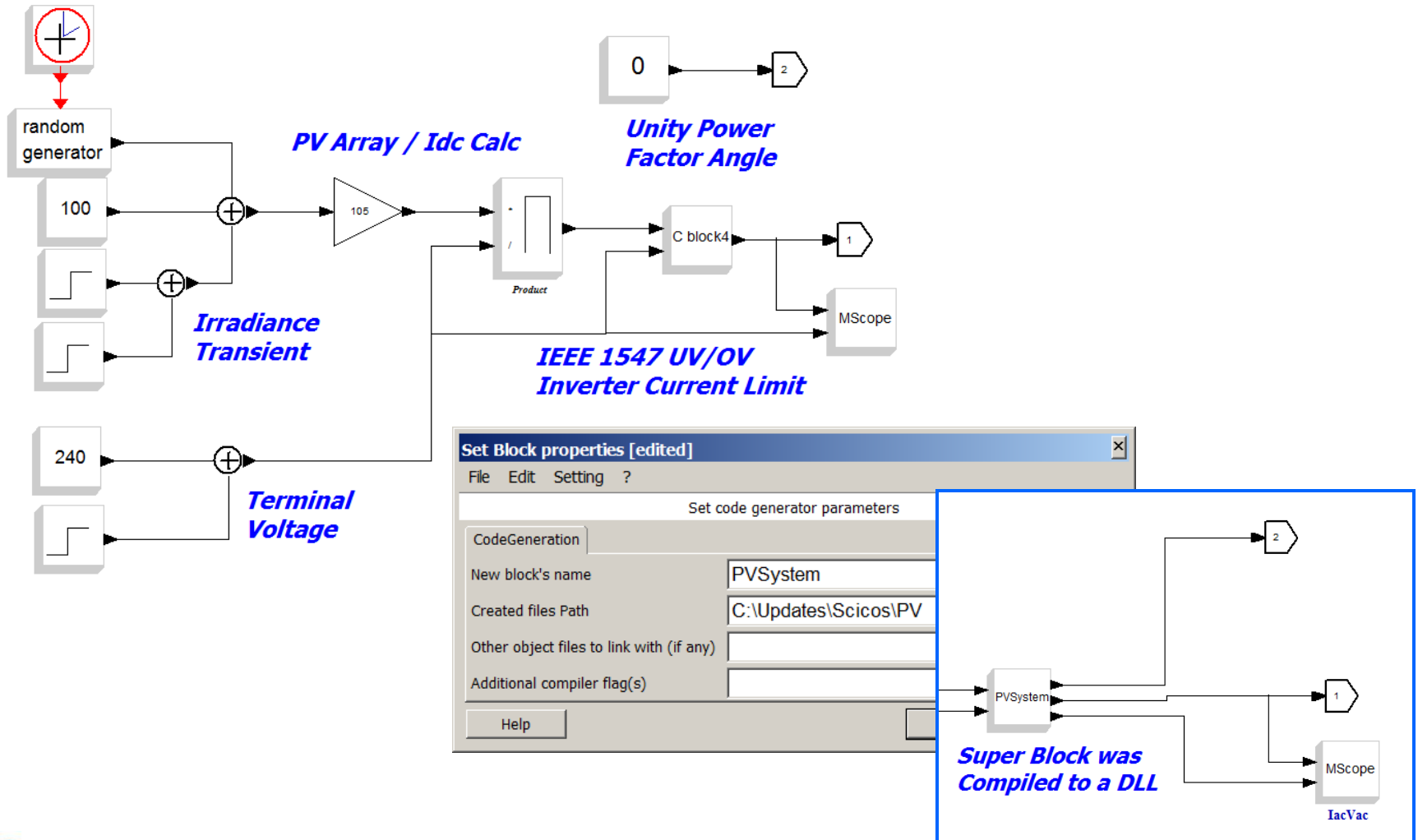

# A “Real” PV Model in Simulink

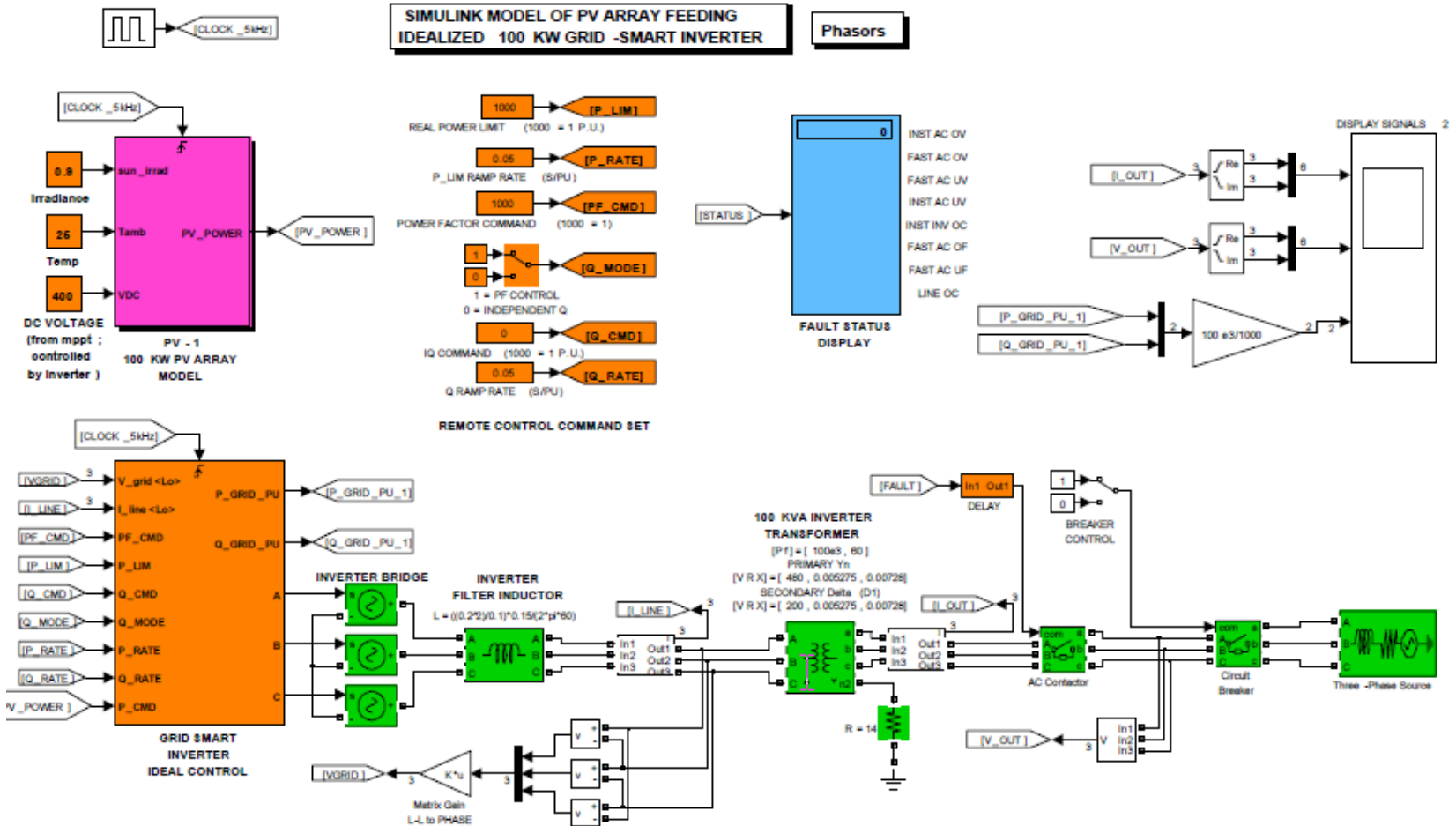

# Controlled Current Source Model

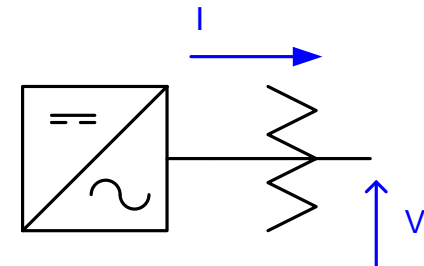
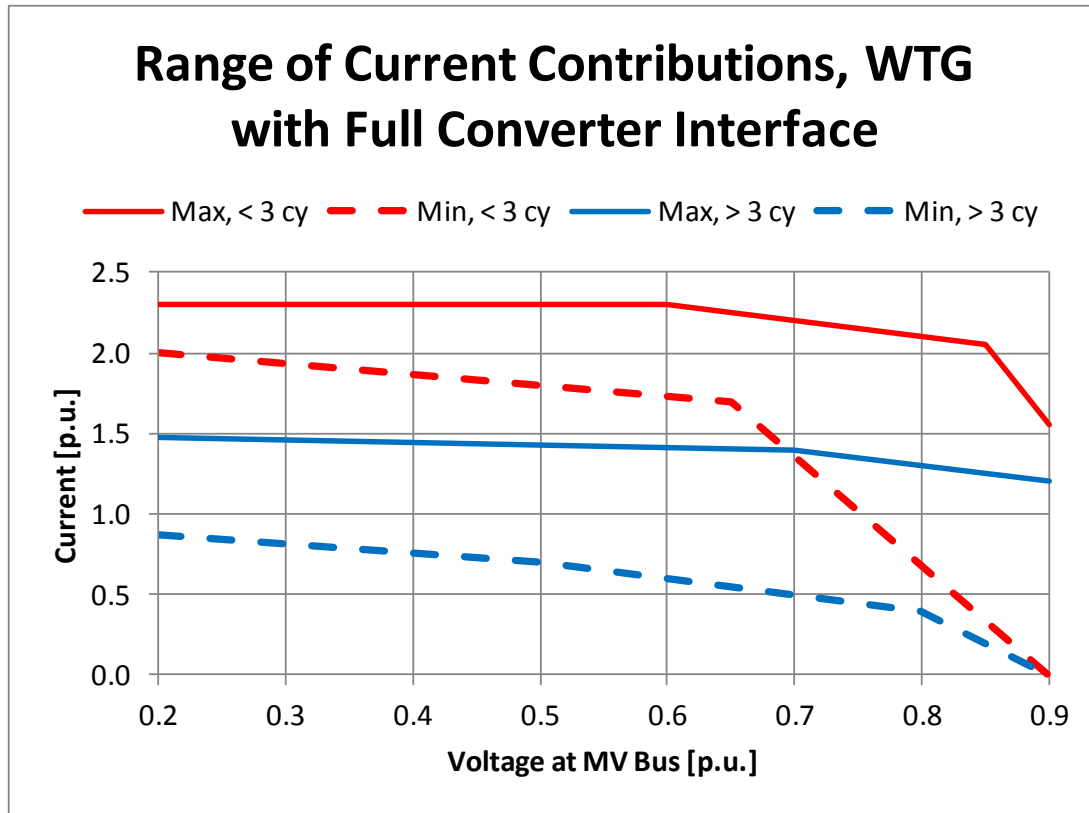

- Walling, Gursoy, English, 2011 IEEE PES General Mtg.
- IEEE P1547.7 and P1547.8 Data Requirements

# Conclusions

---

- ◆ Screening tools and feeder simulator growing up
- ◆ Look for IEEE P1547.8
- ◆ We need:
  - Inverter models from vendors
  - Power quality monitor data from utilities
  - Example feeder models from utilities
- ◆ Two-day interconnection workshop in Golden, CO, February 22-23, 2012